

## PT Push Trolley and GT Geared Trolley

Push trolley capacities from ½ through 10 Ton

Geared trolley capacities from ½ through 20 Ton

Harrington push and geared trolleys help you maneuver easily on your most demanding lifting operations. They feature specially designed contoured wheels that ensure reliable tracking, and their sealed ball bearings avoid maintenance hassles and provide smooth operation.

### Many Benefits From More Features:

- Get sure trolley tracking with specially designed contoured wheels that fit both tapered and flat-flange beams.
- Maintenance-free, sealed precision ball bearings are lubed-for-life and offer smooth movement, with low friction and long life.
- Get strength and rigidity from a lightweight, compact design.
- Easily adjust trolley to fit a wide variety of beam flange widths.
- Load equalizing suspension distributes the load to all wheels.
- Wide standard flange ranges reduce the need for optional extended shaft kits.
- Match the needs of the job with a variety of trolley hoist suspenders.

### Capabilities To Count On:

- Use the economical PT for applications involving longer traversing distances.
- Use the GT for precise load control and shorter traversing distances.
- ½ through 3 Ton are supplied with Suspender C, which is suitable for most applications. Alternate suspenders may be required for your application - see trolley hoist suspenders on page 26.
- Geared trolleys of larger capacities are available. Please consult factory for details.



PT Push Trolley

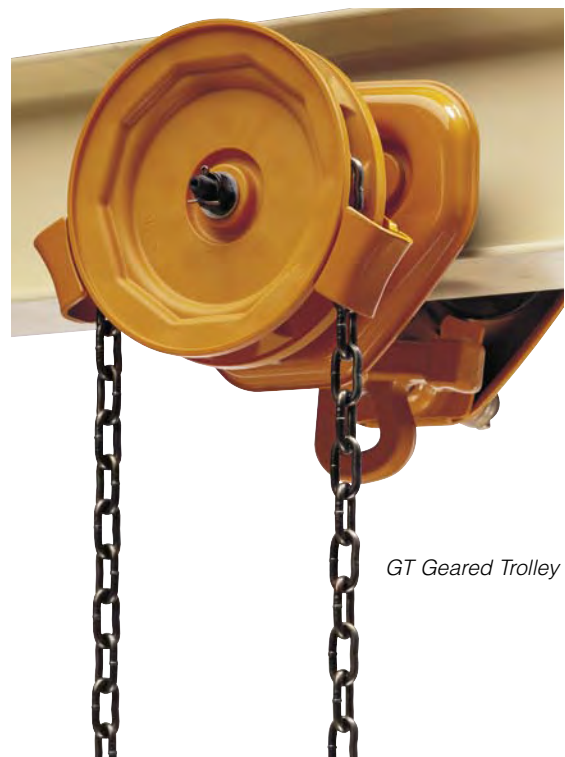

GT Geared Trolley

**PT PUSH TROLLEY — SPECIFICATIONS & DIMENSIONS**

Cap. (Tons)	Product Code	Min. Radius for Curve (in)	Flange Width Adjustability B (in)		a max (in)	a' (in)	b (in)	e (in)	h (in)	i (in)	j (in)	k (in)	m (in)	n (in)	r (in)	s (in)	t (in)	v (in)	Net Weight (lbs)	Shipping Weight (lbs)
			Standard	Option																
1/2	PTF2005	13.8	2.28 to 4.00	4.01 to 8.00 or 8.01 to 12.00	6.8	8.0	7.2	1.8	3.2	2.36	0.80	3.0	2.7	3.3	1.5	B-1.8	0.87	3.7	9	9
1	PTF2010	17.7	2.28 to 5.00	5.01 to 8.00 or 8.01 to 12.00	8.5	9.8	9.3	2.2	4.2	2.80	1.1	3.7	3.1	4.4	2.0	B-1.9	0.98	4.2	15	16
1 1/2-2	PTF2020	21.7	3.23 to 6.02	6.03 to 12.00	10.4	11.8	11.0	2.7	5.0	3.35	1.4	4.4	3.8	5.2	2.4	B-2.3	1.26	5.1	29	30
2 1/2-3	PTF2030	25.6			11.0	12.6	12.8	3.1	5.8	3.94		5.3	4.3	6.0	2.7		1.42	6.7	46	47
5	PTF2050	78.7	4.92 to 7.02	7.03 to 12.00	10.7	11.7	13.7	2.1	5.7	4.65	—	5.7	3.6	7.0	4.6	B-3.0	1.73	3.7	95	98
8	PT080	118.1	5.50 to 8.66	8.67 to 12.00	14.4	17.6	18.9	4.1	7.3	6.10		6.7	5.9	7.7	6.0	B-3.6	2.76	4.6	212	254
10	PT100																			

Weights are approximate.

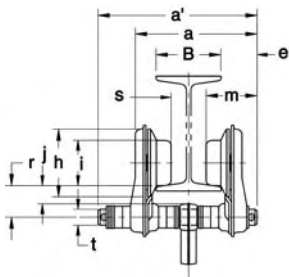

1/2 – 3 Ton

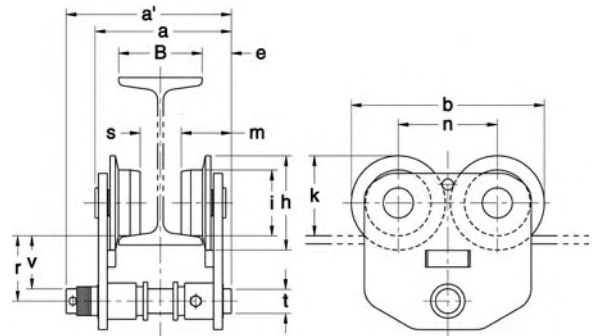
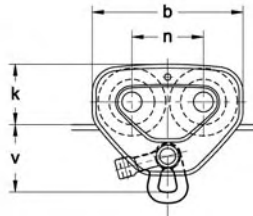

5 – 10 Ton

**GT GEARED TROLLEY — SPECIFICATIONS & DIMENSIONS**

Cap. (Tons)	Product Code	Min. Radius for Curve (in)	Flange Width Adjustability B (in)		a max (in)	a' (in)	b (in)	e (in)	f* (ft)	h (in)	i (in)	j (in)	k (in)	k' (in)	m (in)	n (in)	r (in)	s (in)	t (in)	u (in)	v (in)	Net Weight (lbs)	Shipping Weight (lbs)
			Standard	Option																			
1/2-1	GTF2010	17.7	2.28 to 5.00	5.01 to 8.00 or 8.01 to 12.00	10.8	12.2	9.3	4.6	8	4.2	2.80	1.1	3.7	4.2	2.2	4.4	2.0	B-1.9	0.98	7.2	4.2	24	25
1 1/2-2	GTF2020	21.7	3.23 to 6.02	6.03 to 12.00	13.7	15.2	11.0	6.1		5.0	3.35	1.4	4.4	4.3	2.8	5.2	2.4	B-2.3	1.26		5.1	37	39
2 1/2-3	GTF2030	25.6			14.1	15.7	12.8	6.2		5.8	3.94		5.3	4.5	3.1	6.0	2.7		1.42		6.7	55	57
5	GTF2050	78.7	4.92 to 7.02	7.03 to 12.00	14.8	15.7	13.7	6.1	5.7	4.65	—	5.7	5.2	3.2	7.0	4.6	B-3.0	1.73	3.7	104	107		
8	GT080	118.1	5.50 to 8.66	8.67 to 12.00	17.4	20.6	18.9	7.0	12	7.3		6.10	6.7	6.5	4.7	7.7	6.0	B-3.6	2.76	8.4	4.6	218	260
10	GT100																						
15	GT150	∞	5.50 to 8.66	8.67 to 12.00	22.7	21.3	39.8							8.9	28.2	8.0			3.15	6.3	534	615	
20	GT200																						

\*Longer hand chain drops available upon request.  
Weights are approximate.

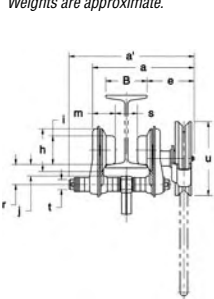

1/2 – 3 Ton

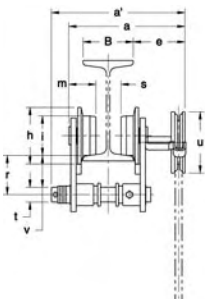
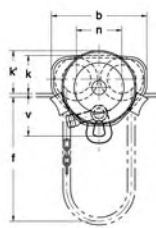

5 – 10 Ton

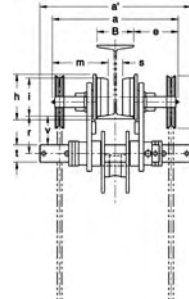

15 – 20 Ton

